

**Quick Reference Guide**  
**Kurzanleitung**  
**Guide de référence rapide**  
**Beknopte bedieningshandleiding**  
**Guida di riferimento rapido**  
**Guía de referencia rápida**  
**Guia de referència rápida**  
**Краткий справочник**

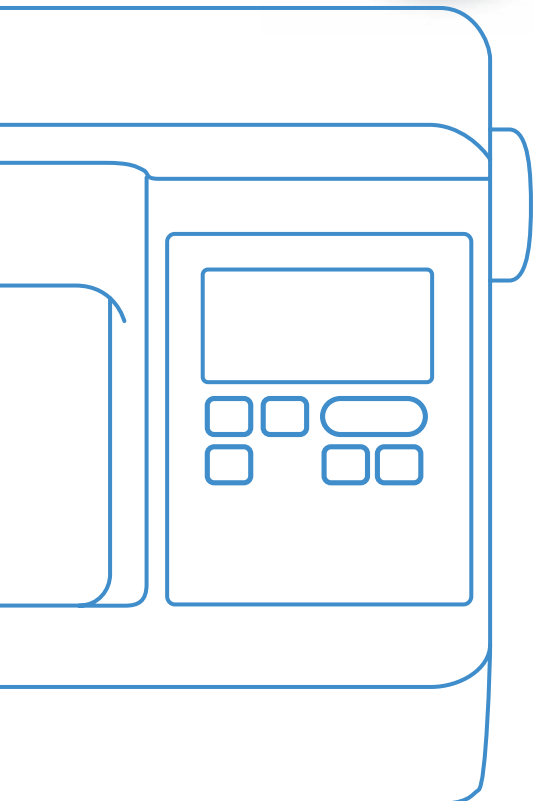

Be sure to read this document before using the machine.  
We recommend that you keep this document nearby for future reference.

Lesen Sie dieses Dokument, bevor Sie die Maschine verwenden.  
Es wird empfohlen, dieses Dokument griffbereit aufzubewahren, damit Sie jederzeit darin nachschlagen können.

Veillez à lire ce document avant d'utiliser la machine.  
Nous vous conseillons de conserver ce document à portée de main pour vous y référer ultérieurement.

Lees dit document voordat u de machine gebruikt.  
Houd dit document bij de hand, zodat u het kunt raadplegen.

Leggere questo documento prima di utilizzare la macchina.  
Si consiglia di conservare questo documento a portata di mano per un eventuale riferimento futuro.

Lea este documento antes de utilizar la máquina.  
Recomendamos que tenga este documento a mano por si necesita consultarlo más adelante.

Certifique-se de ler este documento antes de utilizar a máquina.  
Recomendamos guardar este documento em um lugar de fácil acesso para futuras referências.

Обязательно прочитайте этот документ перед началом работы на машине!  
Рекомендуется хранить данный документ в удобном месте, чтобы он был доступен для справок.

**Before using your machine for the first time please read the “IMPORTANT SAFETY INSTRUCTIONS” in the Operation Manual.**

Refer to the Operation Manual for detailed instructions.

In this guide, English screens are used for basic explanations.

For details on the built-in embroidery patterns, refer to the Embroidery Design Guide.

**Bevor Sie die Maschine zum ersten Mal verwenden, lesen Sie bitte „WICHTIGE SICHERHEITSHINWEISE“ in der Bedienungsanleitung.**

Ausführliche Hinweise finden Sie in der Bedienungsanleitung.

In dieser Anleitung werden für die grundlegenden Erläuterungen englischsprachige Bildschirme verwendet.

Weitere Informationen zu den internen Stickmustern finden Sie in dem Stickmuster-Katalog.

**Avant d'utiliser votre machine pour la première fois, veuillez lire les « INSTRUCTIONS DE SÉCURITÉ IMPORTANTES » indiquées dans le manuel d'instructions.**

Reportez-vous au manuel d'instructions pour des informations détaillées.

Les écrans de ce guide sont en Anglais pour les explications de base.

Pour plus de détails sur les motifs de broderie intégrés, consultez le guide de motifs de broderie.

**Lees – voordat u de machine de eerste keer gebruikt – de “BELANGRIJKE VEILIGHEIDSINSTRUCTIES” in de Bedieningshandleiding.**

In de bedieningshandleiding vindt u uitvoerige aanwijzingen.

In deze gids worden Engelse schermen gebruikt bij de uitleg van basisbewerkingen.

Meer bijzonderheden over de ingebouwde borduurpatronen vindt u in de Borduurontwerpen bedieningshandleiding.

**Prima di utilizzare la macchina per la prima volta, leggere “IMPORTANTI ISTRUZIONI DI SICUREZZA” nel manuale d'istruzione.**

Per le istruzioni dettagliate, consultare il manuale di istruzioni.

Nella presente guida si utilizzano le schermate in inglese per le spiegazioni di base.

Per i dettagli sui motivi da ricamo incorporati, consultare la Guida ai ricami.

**Antes de utilizar la máquina por primera vez, lea las “INSTRUCCIONES DE SEGURIDAD IMPORTANTES” en el Manual de instrucciones.**

Consulte las instrucciones detalladas en el manual de instrucciones.

En esta guía, para las explicaciones básicas se utilizan pantallas en inglés.

Para más detalles acerca de los patrones de bordado embutidos, consulte la Guía de diseños de bordado.

**Antes de utilizar a sua máquina pela primeira vez, leia as “INSTRUÇÕES DE SEGURANÇA IMPORTANTES” no Manual de Operações.**

Consulte o manual de operações para obter instruções detalhadas.

Neste manual, as telas em inglês são usadas para as explicações básicas.

Para obter detalhes sobre os padrões de bordado incluídos, consulte o Guia de desenhos de bordado.

**Перед первым использованием машины прочитайте раздел “ВАЖНЫЕ ИНСТРУКЦИИ ПО БЕЗОПАСНОСТИ” в Руководстве пользователя.**

Подробные инструкции см. в руководстве пользователя.

В данном руководстве в качестве иллюстраций используются англоязычные экраны.

Подробная информация о встроенных рисунках для вышивания приведена в Руководстве по дизайнам для вышивания.

## Contents

|   |
|---|
| <b>Wireless Network Connection Functions</b> ..... 3            |
| ◆ Operations available with a wireless network connection ... 3 |
| ◆ Wireless network connection ..... 4                           |
| <b>Winding/Installing the Bobbin</b> ..... 7                    |
| <b>Upper Threading</b> ..... 9                                  |
| <b>Preparing to Embroider</b> ..... 11                          |
| <b>Selecting Embroidery Patterns</b> ..... 13                   |

## Table des matières

|  |
|--|
| <b>Fonctions de connexion au réseau sans fil</b> ..... 3             |
| ◆ Opérations disponibles avec une connexion au réseau sans fil ... 3 |
| ◆ Connexion au réseau sans fil ..... 4                               |
| <b>Bobinage/installation de la canette</b> ..... 7                   |
| <b>Enfilage supérieur</b> ..... 9                                    |
| <b>Préparation de la broderie</b> ..... 11                           |
| <b>Sélection des motifs de broderie</b> ..... 13                     |

## Sommario

|   |
|---|
| <b>Funzioni di connessione di rete wireless</b> ..... 3             |
| ◆ Operazioni disponibili con una connessione di rete wireless ... 3 |
| ◆ Connessione di rete wireless ..... 4                              |
| <b>Avvolgimento/Installazione della spolina</b> ..... 7             |
| <b>Infilatura superiore</b> ..... 9                                 |
| <b>Preparativi per il ricamo</b> ..... 11                           |
| <b>Come selezionare i ricami</b> ..... 13                           |

## Índice

|   |
|---|
| <b>Funções de conexão de rede sem fio</b> ..... 3                     |
| ◆ Operações disponíveis por meio de uma conexão de rede sem fio ... 3 |
| ◆ Conexão de rede sem fio ..... 4                                     |
| <b>Encher/Instalar a bobina</b> ..... 7                               |
| <b>Passagem da linha superior</b> ..... 9                             |
| <b>Preparação para bordar</b> ..... 11                                |
| <b>Seleção de padrões de bordado</b> ..... 13                         |

## Inhalt

|  |
|--|
| <b>Funktionen zur Verbindung mit dem Wireless-LAN</b> ... 3    |
| ◆ Verfügbare Funktionen bei einer Wireless-LAN-Verbindung... 3 |
| ◆ Verbindung per Wireless-LAN ..... 4                          |
| <b>Aufspulen/Einsetzen der Spule</b> ..... 7                   |
| <b>Einfädeln des Oberfadens</b> ..... 9                        |
| <b>Vorbereitung zum Sticken</b> ..... 11                       |
| <b>Auswählen von Stickmustern</b> ..... 13                     |

## Inhoudsopgave

|  |
|--|
| <b>Functies voor draadloze netwerkverbinding</b> ..... 3         |
| ◆ Functie mogelijkheden met een draadloze netwerkverbinding... 3 |
| ◆ Draadloze netwerkverbinding ..... 4                            |
| <b>Spoel opwinden/installeren</b> ..... 7                        |
| <b>Inrijgen van de bovendraad</b> ..... 9                        |
| <b>Vorbereidingen voor borduren</b> ..... 11                     |
| <b>Borduurpatronen selecteren</b> ..... 13                       |

## Contenido

|  |
|--|
| <b>Funciones de conexión de red inalámbrica</b> ..... 3            |
| ◆ Operaciones disponibles con una conexión de red inalámbrica... 3 |
| ◆ Conexión de red inalámbrica ..... 4                              |
| <b>Devanar/colocar la bobina</b> ..... 7                           |
| <b>Hilo superior</b> ..... 9                                       |
| <b>Preparativos para bordar</b> ..... 11                           |
| <b>Seleccionar patrones de bordado</b> ..... 13                    |

## Содержание

|   |
|---|
| <b>Функции подключения к беспроводной сети</b> ..... 3          |
| ◆ Операции, доступные при подключении к беспроводной сети ... 3 |
| ◆ Подключение к беспроводной сети ..... 4                       |
| <b>Намотка/установка шпульки</b> ..... 7                        |
| <b>Заправка верхней нити</b> ..... 9                            |
| <b>Подготовка к вышиванию</b> ..... 11                          |
| <b>Выбор рисунков для вышивания</b> ..... 13                    |



# Wireless Network Connection Functions

## Funktionen zur Verbindung mit dem Wireless-LAN

### Fonctions de connexion au réseau sans fil

### Functies voor draadloze netwerkverbinding

### Funzioni di connessione di rete wireless

### Funciones de conexión de red inalámbrica

### Funções de conexão de rede sem fio

### Функции подключения к беспроводной сети

- ◆ Operations available with a wireless network connection
- ◆ Opérations disponibles avec une connexion au réseau sans fil
- ◆ Operazioni disponibili con una connessione di rete wireless
- ◆ Operações disponíveis por meio de uma conexão de rede sem fio
- ◆ Verfügbare Funktionen bei einer Wireless-LAN-Verbindung
- ◆ Functie mogelijkheden met een draadloze netwerkverbinding
- ◆ Operaciones disponibles con una conexión de red inalámbrica
- ◆ Операции, доступные при подключении к беспроводной сети

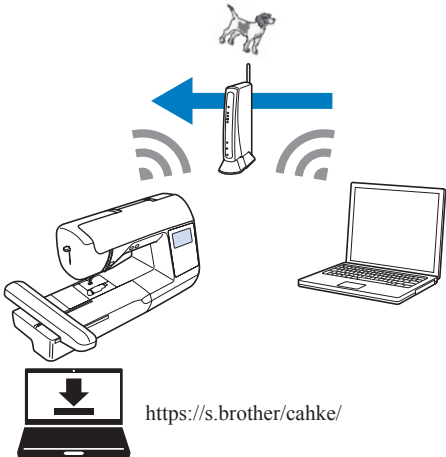
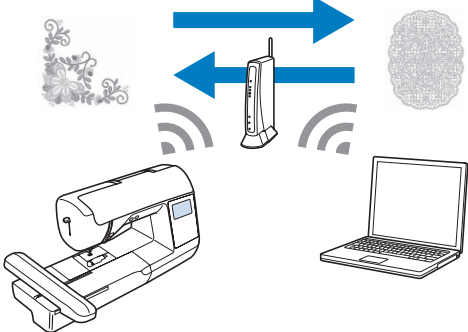
|   |  |   |
|---|--|---|
|  <p><a href="https://s.brother/cahke/">https://s.brother/cahke/</a></p> | <p>Wirelessly transfer an embroidery pattern from your computer to the machine by using the dedicated Windows application (Design Database Transfer).</p> <p>Utilisez une connexion sans fil pour transférer un motif de broderie de votre ordinateur vers la machine grâce à l'application Windows dédiée (Design Database Transfer (Transfert de Base de données de Motifs)).</p> <p>Trasferimento in modalità wireless dei ricami dal computer alla macchina utilizzando l'apposita applicazione Windows (Design Database Transfer).</p> <p>Faça a transferência sem fio de padrões de bordado do seu computador para a máquina por meio do aplicativo dedicado do Windows (Design Database Transfer).</p>  | <p>Übertragen Sie mit Hilfe der speziellen Windows-Anwendung (Design Database Transfer) Stickmuster drahtlos von Ihrem Computer an die Maschine.</p> <p>Breng draadloos een borduurpatroon over van uw computer naar de machine met gebruik van de speciale Windows-toepassing (Design Database Transfer).</p> <p>Transfiera de forma inalámbrica un patrón de bordado desde el ordenador a la máquina utilizando la aplicación específica de Windows (Design Database Transfer).</p> <p>Беспроводная передача дизайна вышивания с компьютера на машину с помощью специального приложения для Windows (Design Database Transfer).</p>   |
|    | <p>Wirelessly transfer to the machine an embroidery pattern edited with embroidery editing software (PE-DESIGN version 11 or later) on a computer. Also, transfer to PE-DESIGN an embroidery pattern edited on the machine.</p> <p>Utilisez une connexion sans fil pour transférer vers la machine un motif de broderie modifié avec le logiciel d'édition de broderie (PE-DESIGN version 11 ou ultérieure) sur un ordinateur. Transférez également vers PE-DESIGN un motif de broderie modifié sur la machine.</p> <p>Trasferimento in modalità wireless alla macchina dei ricami modificati con il software (PE-DESIGN versione 11 o successive) sul computer. Inoltre, trasferimento a PE-DESIGN dei ricami modificati sulla macchina.</p> <p>Faça a transferência sem fio para a máquina de padrões de bordado editados em um computador com o software de edição de bordados (PE-DESIGN versão 11 ou posterior). Além disso, transfira padrões de bordado editados na máquina para o PE-DESIGN.</p> | <p>Übertragen Sie drahtlos ein mit einer Stickeditorssoftware (PE-DESIGN Version 11 oder höher) auf einem Computer bearbeitetes Stickmuster an die Maschine. Sie können auch ein auf der Maschine bearbeitetes Stickmuster an PE-DESIGN übertragen.</p> <p>Breng draadloos een borduurpatroon over naar de machine dat is bewerkt in borduurbewerkingssoftware (PE-DESIGN versie 11 of hoger) op een computer. Eveneens is het mogelijk om 'op de machine bewerkte borduurpatronen' over te brengen naar PE-DESIGN.</p> <p>Transfiera de forma inalámbrica a la máquina un patrón de bordado editado con un programa de edición de bordados (PE-DESIGN versión 11 o posterior) en un ordenador. Igualmente, transfiera a PE-DESIGN un patrón de bordado editado en la máquina.</p> <p>Беспроводная передача на машину дизайна вышивания, отредактированного на компьютере в программе редактирования вышивок (PE-DESIGN версии 11 или выше). Также возможна передача в программу PE-DESIGN дизайна вышивания, отредактированного на машине.</p> |

When an updated version of software is available on our website, the wireless LAN key appears as .

Quand une mise à jour de la version du logiciel est disponible sur notre site Web, la touche du réseau local LAN sans fil apparaît sous la forme .

Quando sul nostro sito Web è disponibile una versione aggiornata del software, il tasto LAN wireless viene visualizzato come .

Quando uma versão atualizada do software está disponível em nosso site, a tecla LAN sem fio aparece como .

Wenn eine aktualisierte Softwareversion auf unserer Website verfügbar ist, wird die Taste „Wireless-LAN“ mit dem Symbol  angezeigt.

Wanneer er een update versie van de software beschikbaar is op onze website, wordt de toets voor WLAN Draadloze verbinding weergegeven als .



Cuando en nuestro sitio web está disponible una versión actualizada del software, la tecla de LAN inalámbrica se muestra como .



Когда на нашем сайте доступна обновленная версия программного обеспечения, кнопка “Беспроводная сеть” имеет вид .



- ◆ Wireless network connection
- ◆ Connexion au réseau sans fil
- ◆ Connessione di rete wireless
- ◆ Conexão de rede sem fio



- ◆ Verbindung per Wireless-LAN
- ◆ Draadloze netwerkverbinding
- ◆ Conexión de red inalámbrica
- ◆ Подключение к беспроводной сети







When you first turn on the machine, the following message about a wireless LAN connection appears.  
To set up a connection, touch , and then continue with step .



Quand vous mettez la machine sous tension pour la première fois, le message suivant apparaît, à propos de la connexion au réseau local LAN sans fil.  
Pour configurer une connexion, appuyez sur , puis continuez en passant à l'étape .



Quando si accende la macchina per la prima volta, viene visualizzato il seguente messaggio relativo a una connessione LAN wireless.  
Per configurare una connessione, toccare  e continuare con il passaggio .

Quando você liga a máquina pela primeira vez, a seguinte mensagem sobre uma conexão de LAN sem fio é exibida.  
Para configurar uma conexão, toque em  e continue da etapa .

Beim ersten Einschalten der Maschine wird die folgende Meldung bezüglich einer Verbindung per Wireless-LAN angezeigt.  
Tippen Sie auf , um eine Verbindung einzurichten. Befolgen Sie dann Schritt .

Wanneer u de machine de eerste keer aan zet, wordt het volgende bericht over een WLAN Draadloze verbinding weergegeven.  
Druk op  als u een verbinding wilt instellen en ga vervolgens door met stap .

Cuando se activa la máquina por primera vez, se muestra el siguiente mensaje acerca de una conexión de LAN inalámbrica.  
Para establecer una conexión, toque  y luego continúe con el paso .

При первом включении машины отображается указанное сообщение о подключении к беспроводной сети.  
Чтобы настроить подключение, нажмите  и перейдите к пункту .

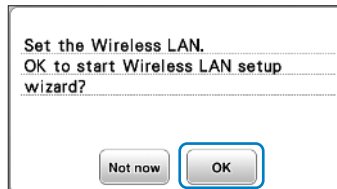

**1** Find your security information (SSID and network key) and note it.  
Recherchez vos informations de sécurité (SSID et clé réseau) et notez-les.  
Cercare le informazioni di sicurezza (nome SSID e chiave di rete) e annotarle.  
Encontre e anote suas informações de segurança (SSID e chave de rede).

Suchen Sie Ihre Sicherheitsinformationen (SSID und Netzwerkschlüssel) heraus und notieren Sie sie.  
Zoek uw beveiligingsgegevens (SSID en netwerksleutel) op en noteer deze.  
Busque su información de seguridad (SSID y clave de red) y anótela.  
Найдите данные безопасности своей беспроводной сети (название SSID и сетевой ключ) и запишите их.

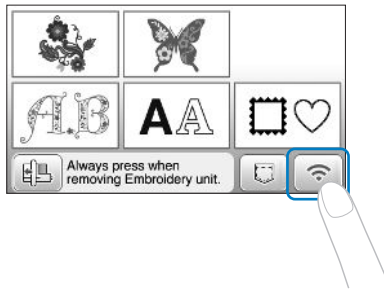
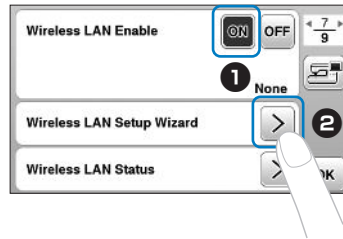
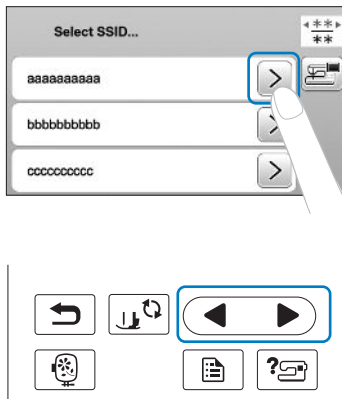
**2****3****4**

Touch **>** beside the SSID that was noted in step **1**.

- When displaying next or previous pages, touch **<** or **>** key to search the SSID that was noted.

Tippen Sie neben der in Schritt **1** notierten SSID auf **>**.

- Wird eine der nächsten oder vorherigen Seiten angezeigt, tippen Sie auf die Taste **<** oder **>**, um die notierte SSID zu suchen.

Appuyez sur **>** à côté du SSID que vous avez noté lors de l'étape **1**.

- Lorsqu'une page suivante ou précédente est affichée, appuyez sur **<** ou **>** pour chercher le SSID que vous avez noté.

Druk op **>** naast de SSID die u hebt genoteerd in stap **1**.

- Wanneer u een volgende of vorige pagina weergeeft, drukt u op de toets **<** of **>** om te zoeken naar de SSID die u hebt genoteerd.

Toccare **>** accanto all'SSID annotato al passaggio **1**.

- Quando si visualizzano le pagine precedenti o successive, toccare il tasto **<** o **>** per cercare l'SSID precedentemente annotato.

Toque **>** que se muestra junto al SSID que se ha anotado en el paso **1**.

- Cuando se muestren las páginas siguientes o anteriores, toque la tecla **<** o **>** para buscar el SSID que se ha anotado.

Toque em **>** ao lado do SSID anotado na etapa **1**.

- Ao exibir as páginas seguintes ou anteriores, toque na tecla **<** ou **>** para pesquisar o SSID anotado.

Нажмите **>** рядом с именем беспроводной сети (SSID), которое вы записали в пункте **1**.

- Если отображается следующая или предыдущая страница, нажмите **<** или **>** для поиска нужного имени беспроводной сети (SSID).

5

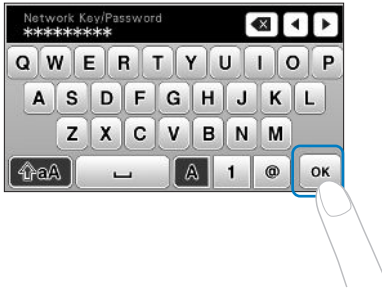

- Enter the network key (password) that was noted, and then touch **OK**.
- Geben Sie den notierten Netzwerkschlüssel (Passwort) ein und tippen Sie dann auf **OK**.
- Saisissez la clé réseau (mot de passe) que vous avez notée, puis appuyez sur **OK**.
- Voer de netwerksleutel (wachtwoord) in die u hebt genoteerd en druk vervolgens op **OK**.
- Inserire la chiave di rete (password) che è stata annotata e premere **OK**.
- Seleccione la clave de red (contraseña) que se ha anotado y toque **OK**.
- Insira a chave de rede (senha) anotada e toque em **OK**.
- Введите записанный сетевой ключ (пароль) и нажмите **OK**.

6

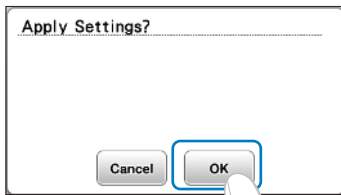

7

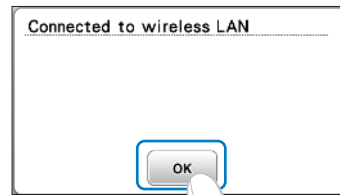

8

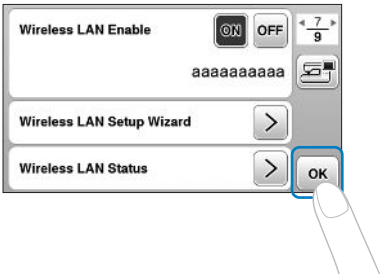

- Touch **OK** to exit the setup.
- Tippen Sie auf **OK**, um die Einrichtung zu verlassen.
- Appuyez sur **OK** pour quitter la procédure de configuration.
- Druk op **OK** om de installatie af te sluiten.
- Premere **OK** per uscire dalla configurazione.
- Toque **OK** para salir de la configuración.
- Toque em **OK** para sair da configuração.
- Нажмите **OK** для выхода из режима настройки.



# Winding/Installing the Bobbin

## Aufspulen/Einsetzen der Spule

### Bobinage/installation de la canette

#### Spool opwinden/installeren

#### Avvolgimento/Installazione della spolina

#### Devanar/colocar la bobina

#### Encher/Instalar a bobina

#### Намотка/установка шпульки

Follow the steps below in numerical order. Refer to the Operation Manual for detailed instructions.  
 Führen Sie die folgenden Schritte in der numerischen Reihenfolge aus. Ausführliche Hinweise finden Sie in der Bedienungsanleitung.  
 Respectez les étapes ci-dessous, dans l'ordre numérique. Reportez-vous au manuel d'instructions pour des informations détaillées.  
 Volg onderstaande stappen in numerieke volgorde. In de bedieningshandleiding vindt u uitvoerige aanwijzingen.  
 Seguire i passaggi di seguito, in ordine numerico. Per le istruzioni dettagliate, consultare il manuale di istruzioni.  
 Siga los pasos descritos a continuación, en orden numérico. Consulte las instrucciones detalladas en el manual de instrucciones.  
 Siga as etapas abaixo, em ordem numérica. Consulte o manual de operações para obter instruções detalhadas.  
 Выполните описанные ниже действия по порядку номеров. Подробные инструкции см. в руководстве пользователя.

Use only the included bobbin or bobbins of the same type.  
 Verwenden Sie nur die im Lieferumfang enthaltene Spule oder Spulen vom selben Typ.  
 N'utilisez que la canette fournie ou des canettes du même type.  
 Gebruik uitsluitend de bijgeleverde spool of spoelen van hetzelfde type.  
 Utilizzare solo la bobina o le bobine in dotazione dello stesso tipo.  
 Utilice solo la bobina incluida, o bobinas del mismo tipo.  
 Somente use a bobina incluída ou bobinas do mesmo tipo.  
 Используйте только прилагаемые шпульки или шпульки того же типа.

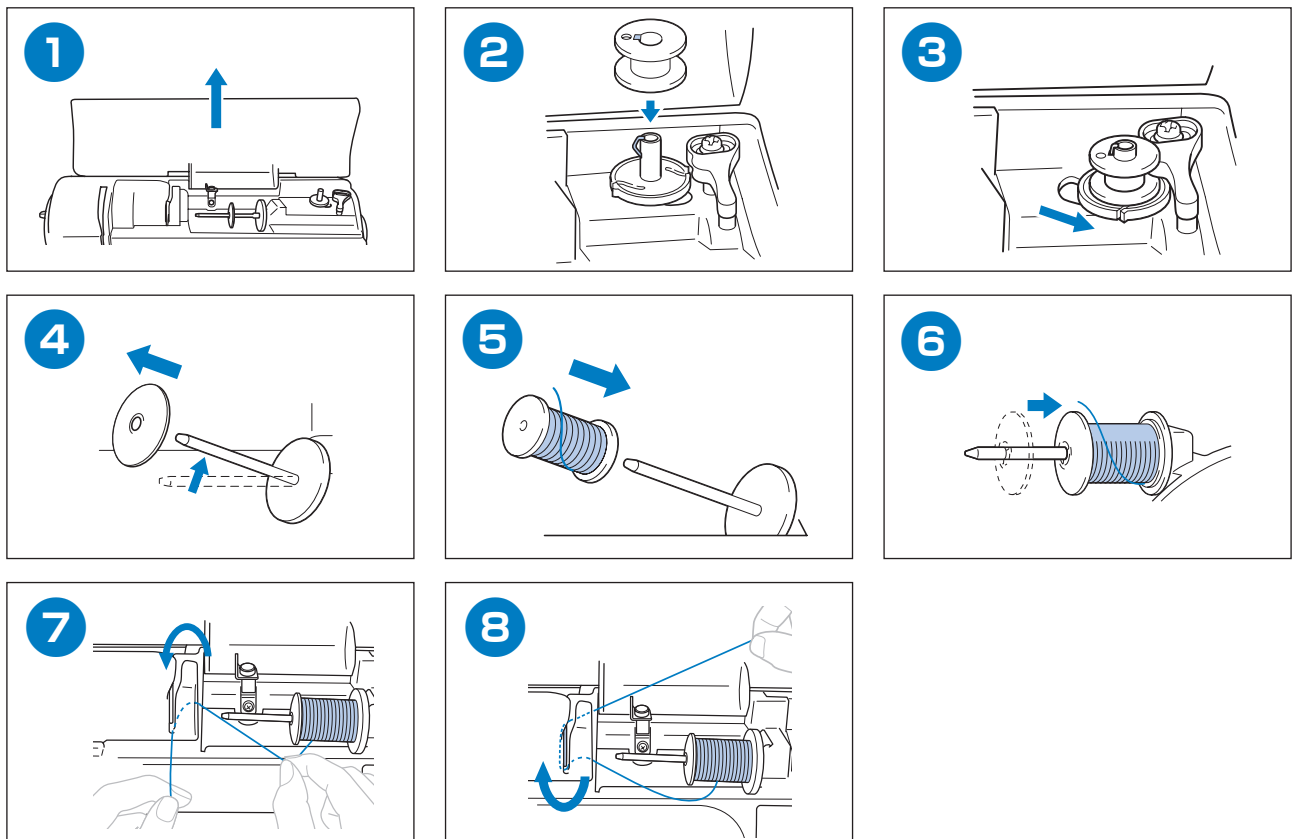
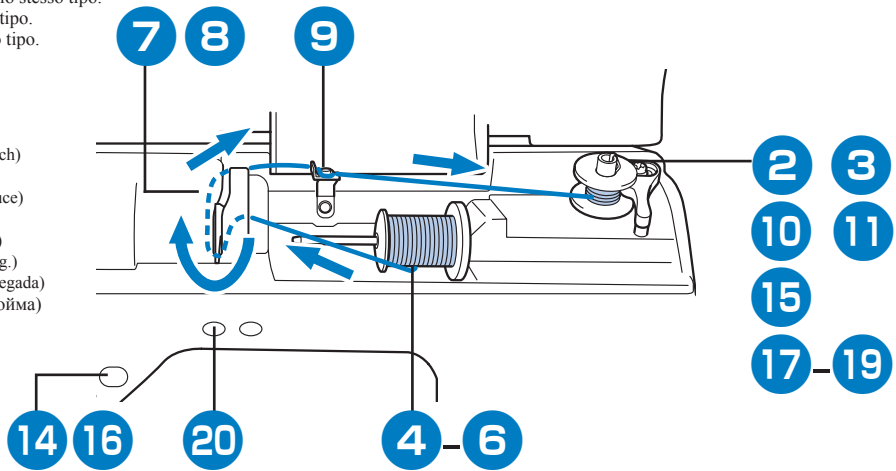
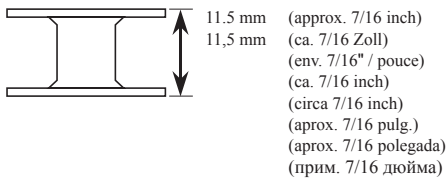

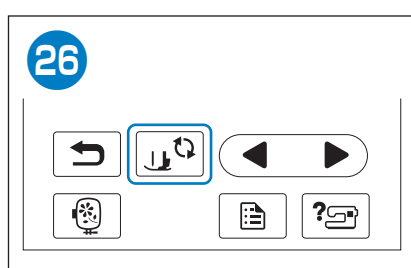
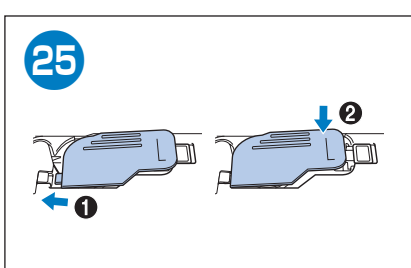
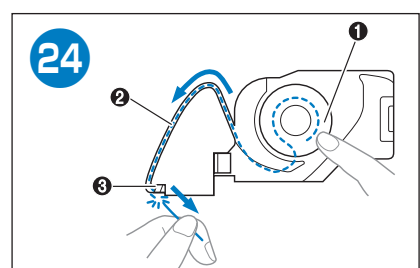
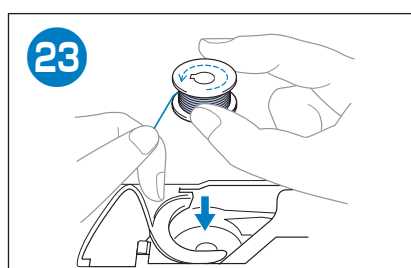
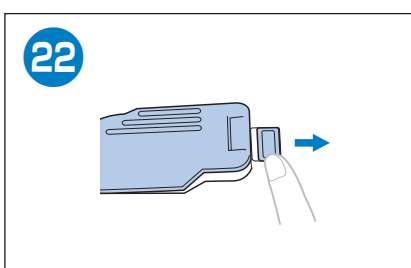
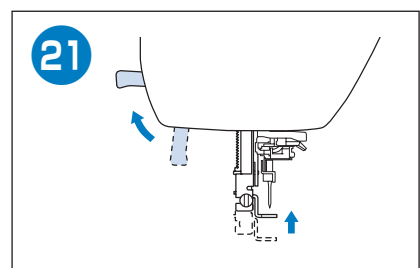
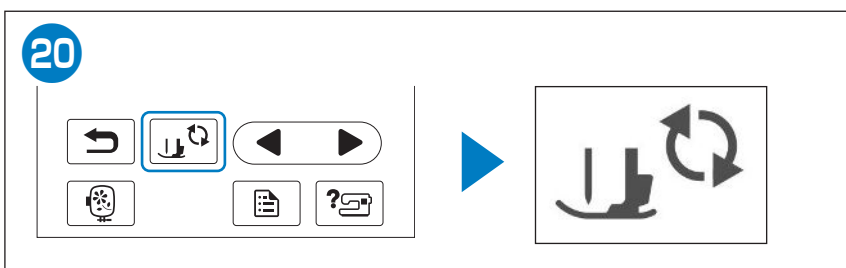
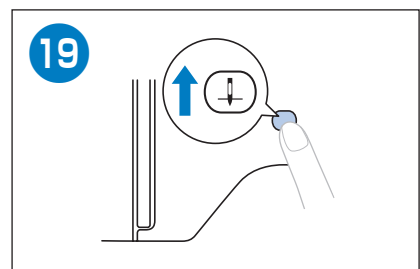
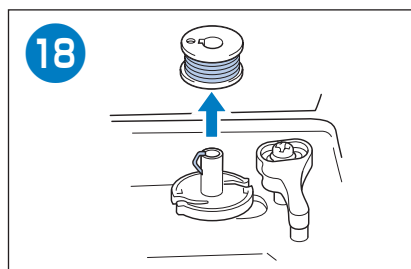
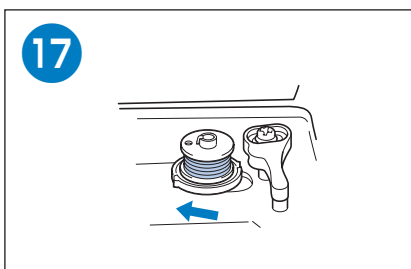
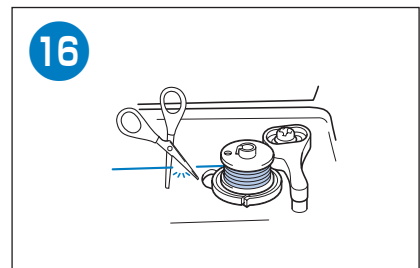
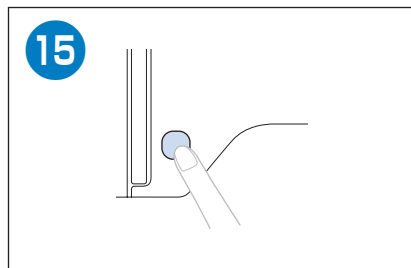
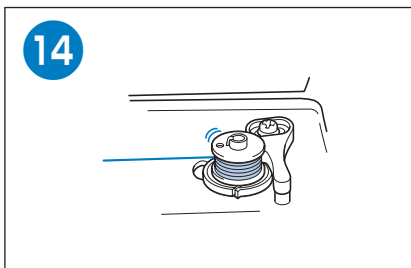
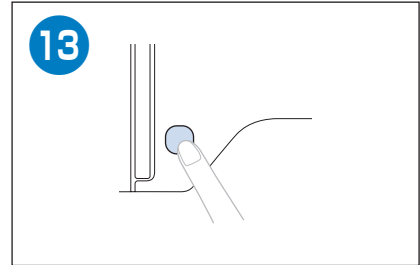
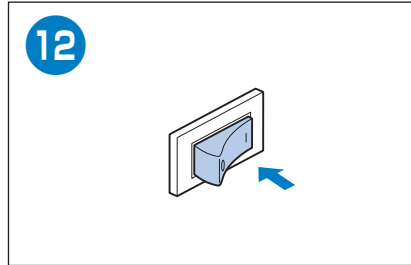
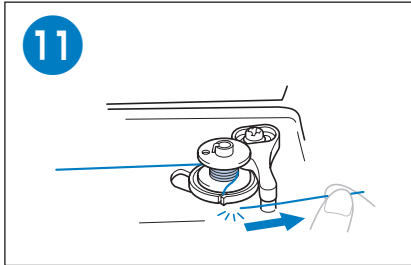
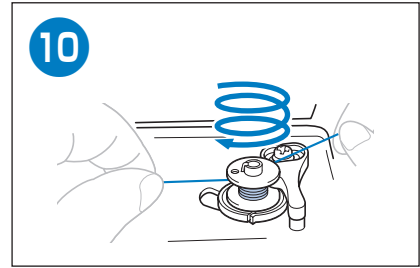
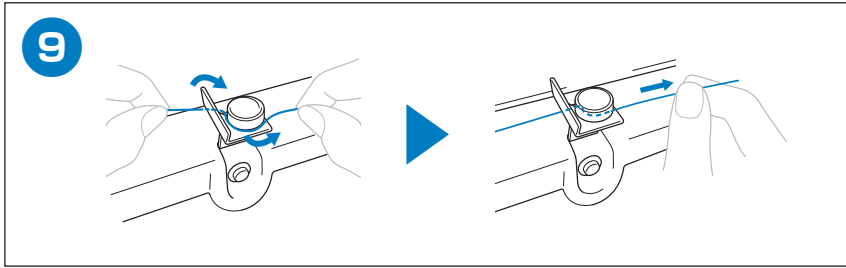



**Upper Threading**  
**Einfädeln des Oberfadens**  
**Enfilage supérieur**  
**Inrijgen van de bovendraad**  
**Infilatura superiore**  
**Hilo superior**  
**Passagem da linha superior**  
**Заправка верхней нити**

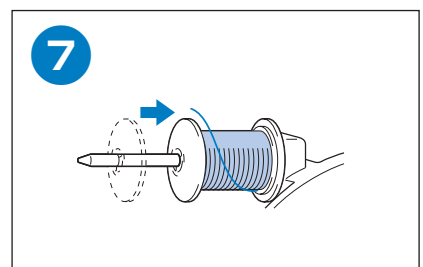
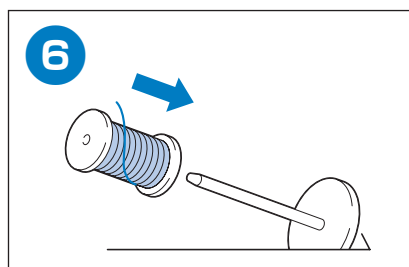
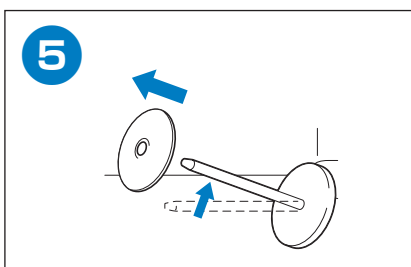
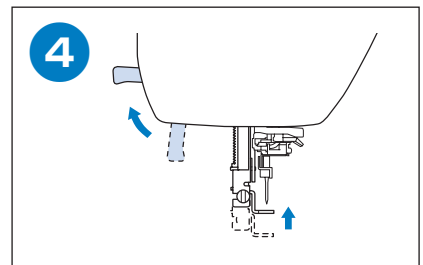
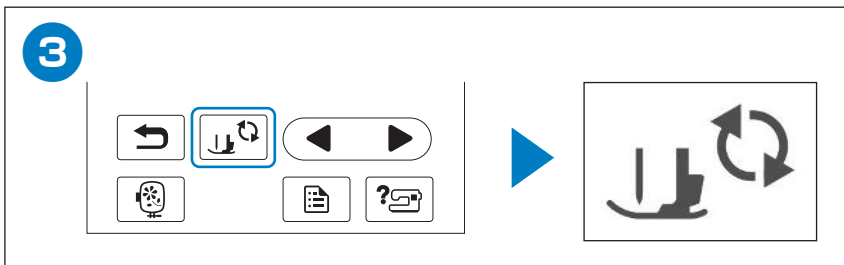
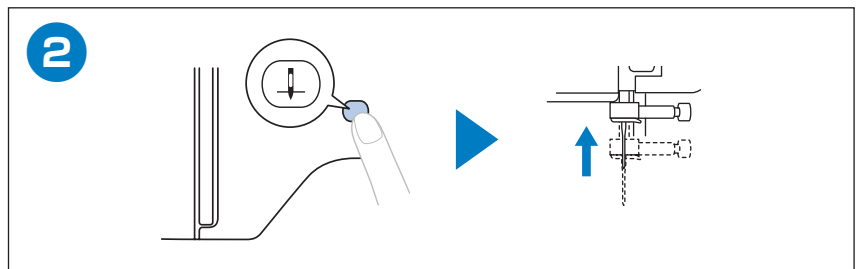
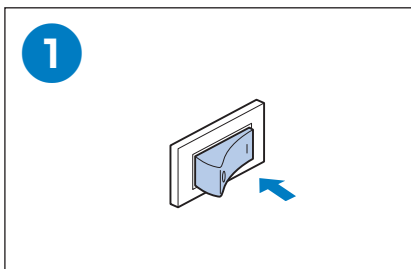
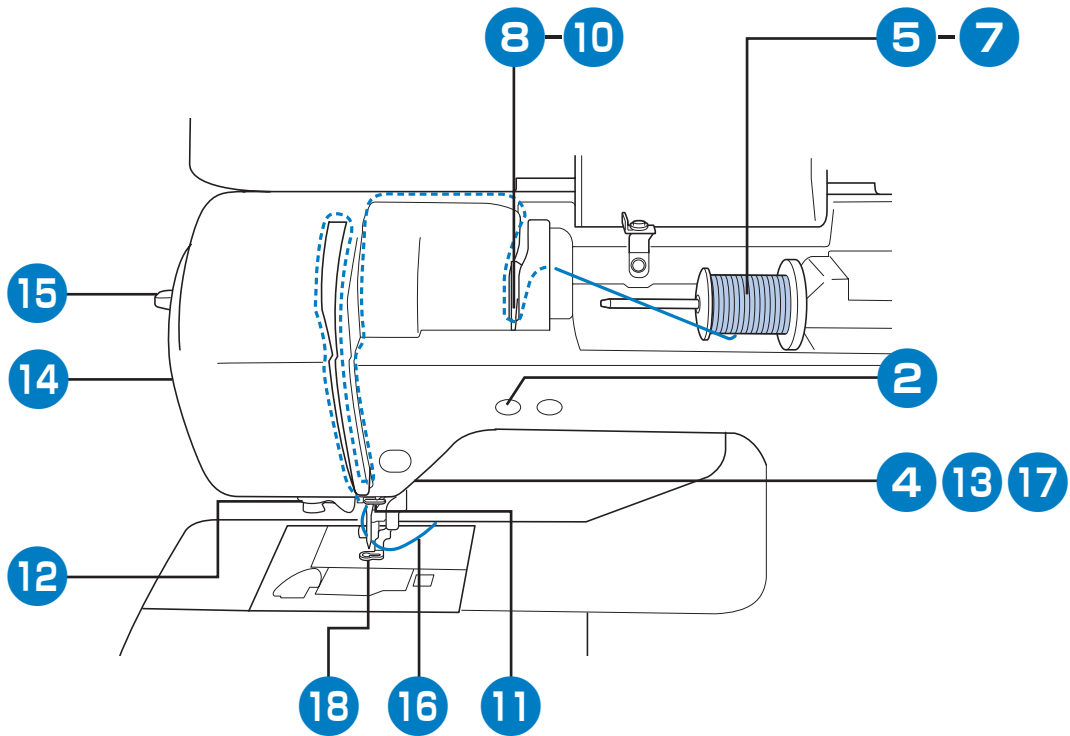

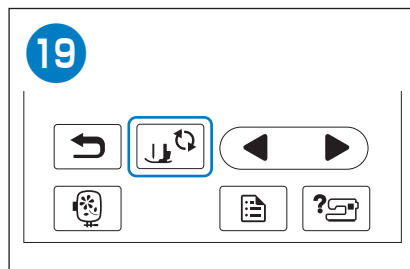
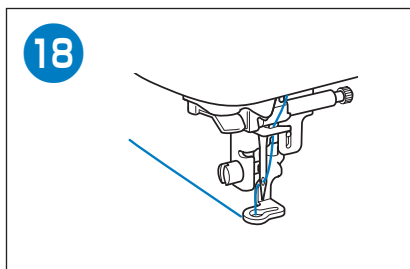
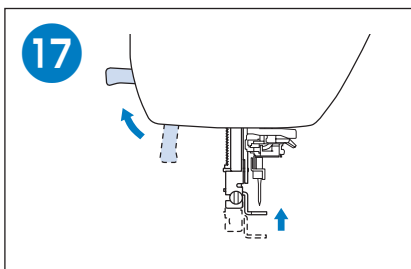
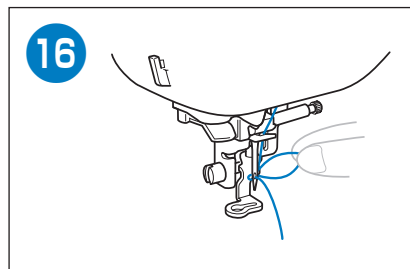
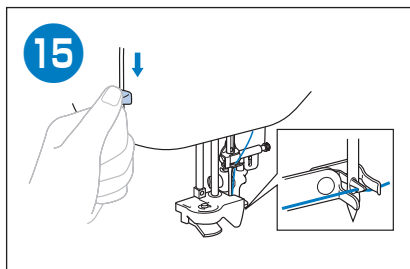
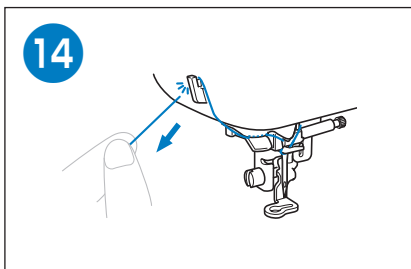
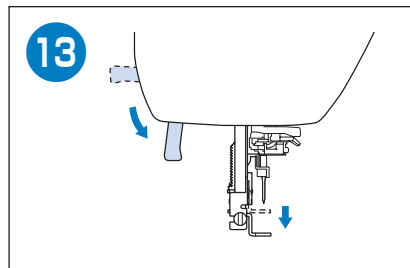
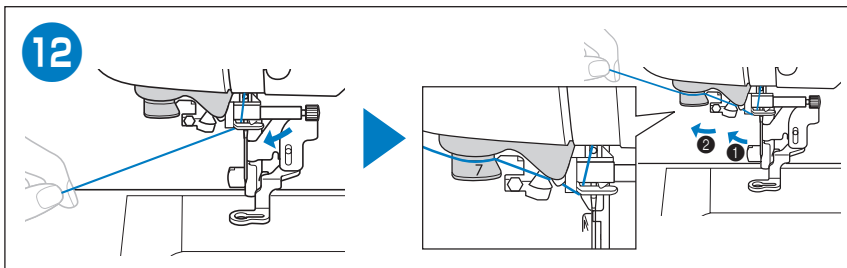
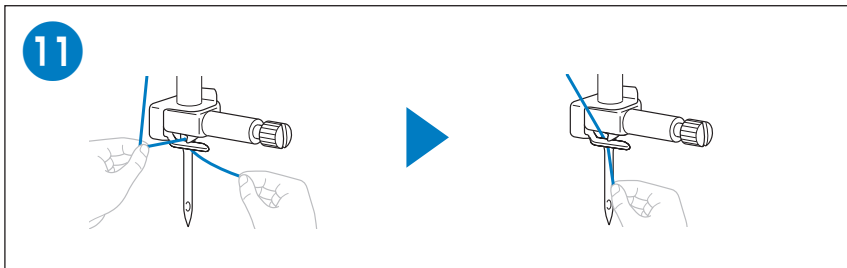
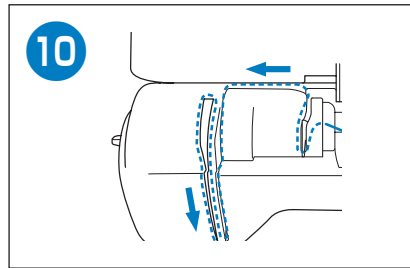
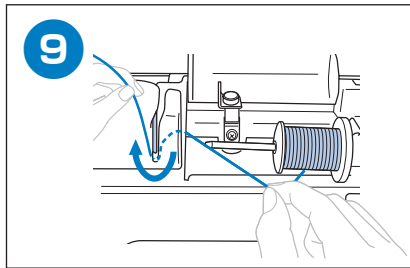
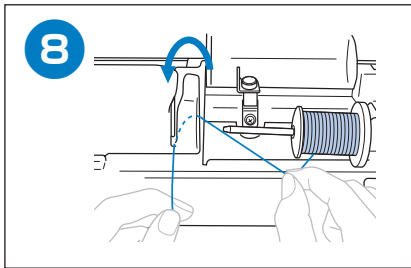



**Preparing to Embroider**  
**Vorbereitung zum Sticken**  
**Préparation de la broderie**  
**Vorbereidingen voor borduren**  
**Preparativi per il ricamo**  
**Preparativos para bordar**  
**Preparação para bordar**  
**Подготовка к вышиванию**

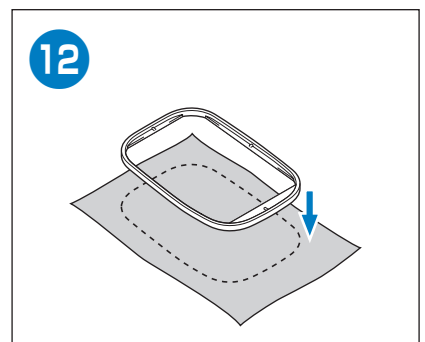
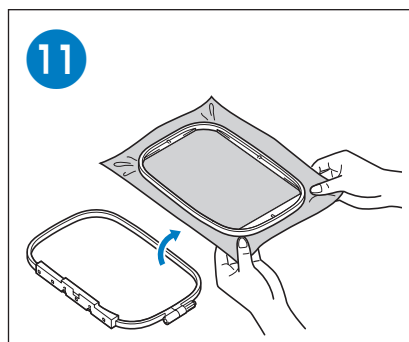
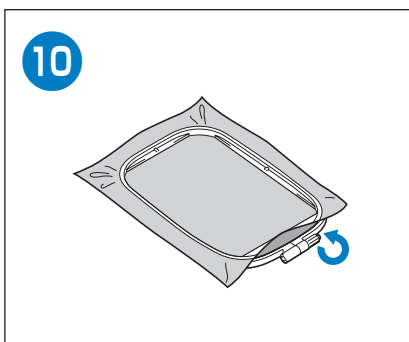
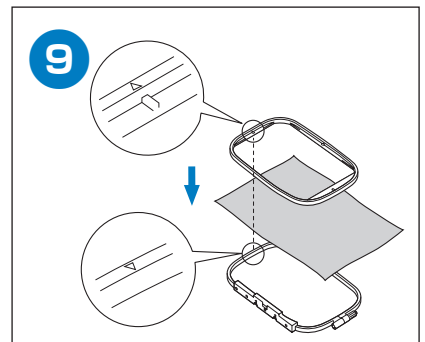
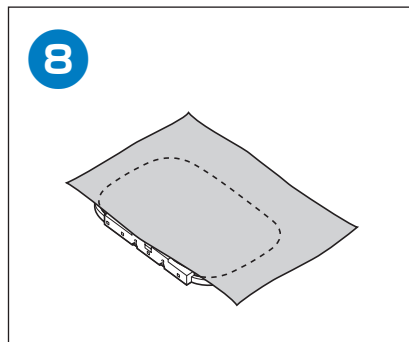
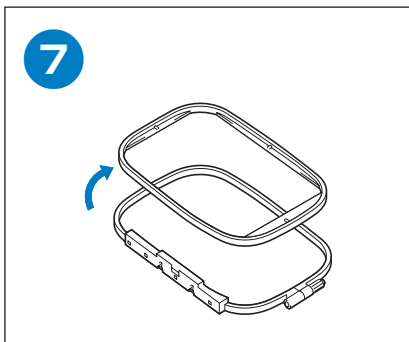
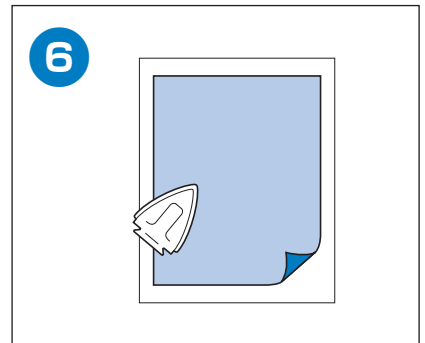
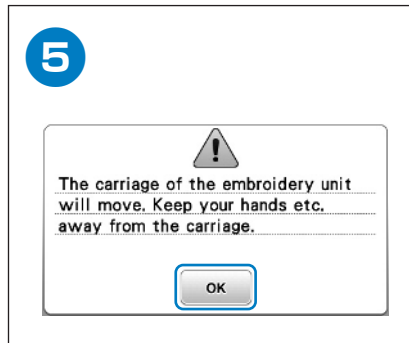
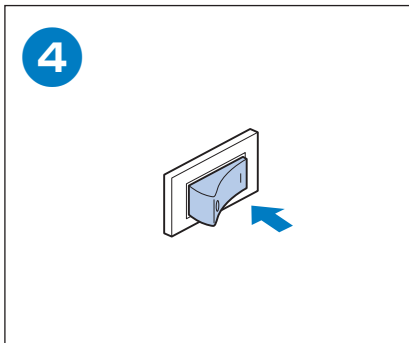
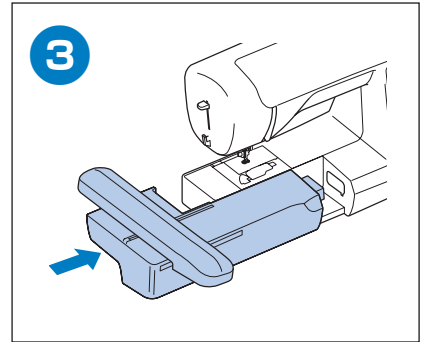
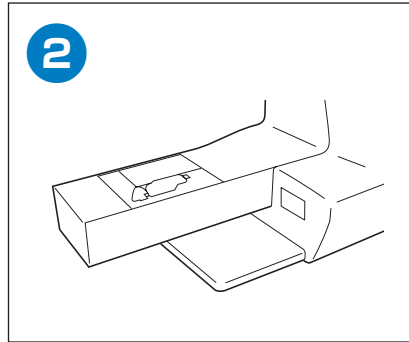
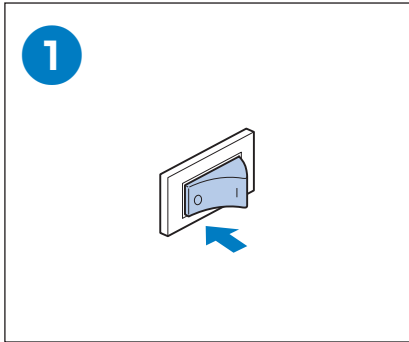

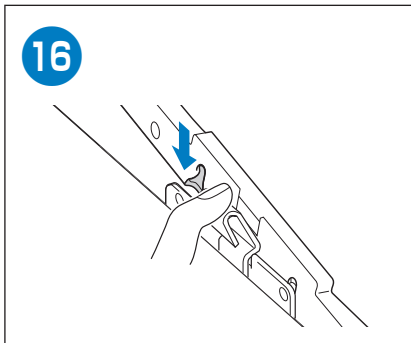
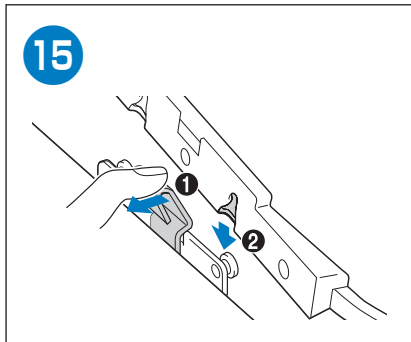
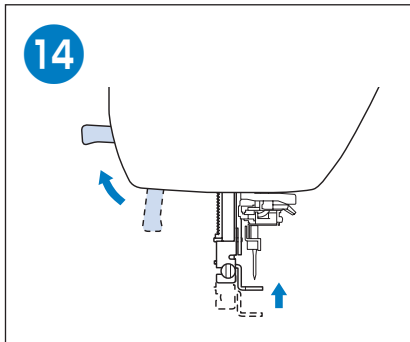
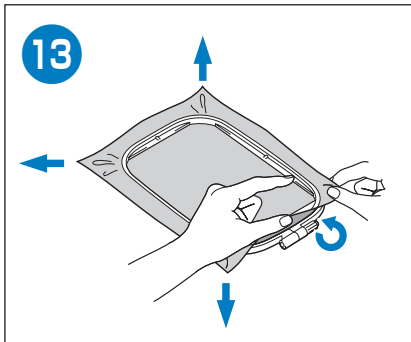



**Selecting Embroidery Patterns**  
**Auswählen von Stickmustern**  
**Sélection des motifs de broderie**  
**Borduurpatronen selecteren**  
**Come selezionare i ricami**  
**Seleccionar patrones de bordado**  
**Seleção de padrões de bordado**  
**Выбор рисунков для вышивания**

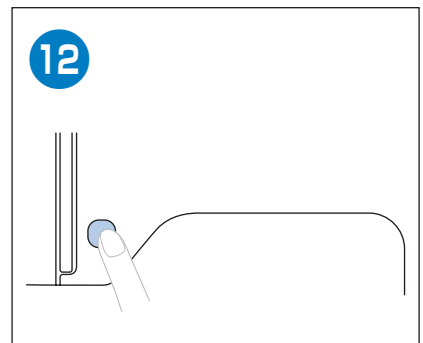
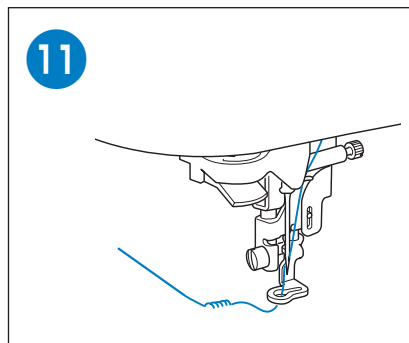
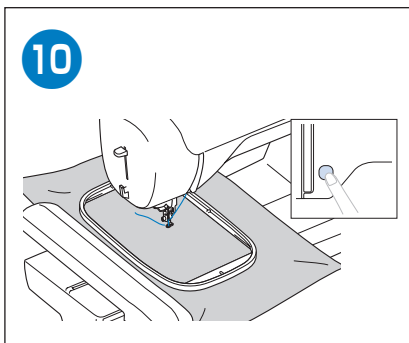
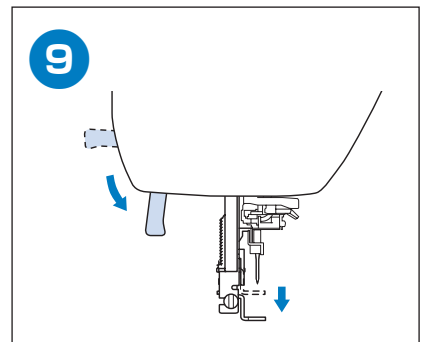
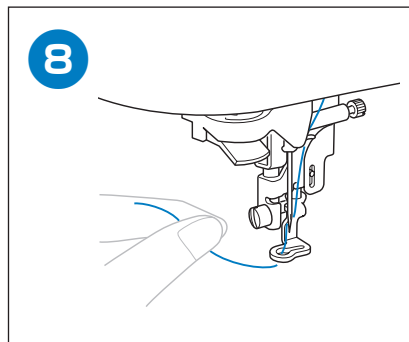
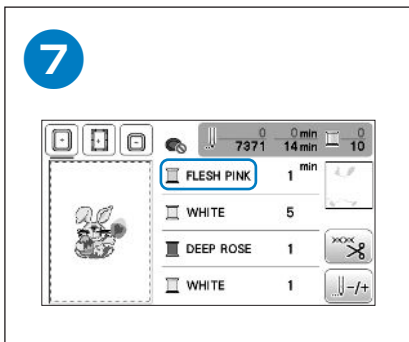
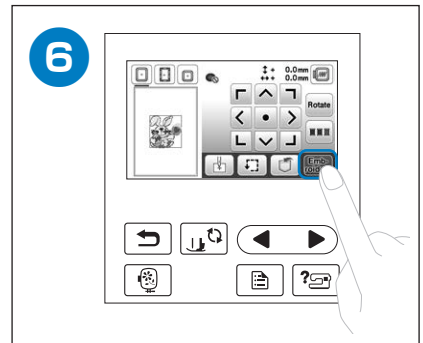
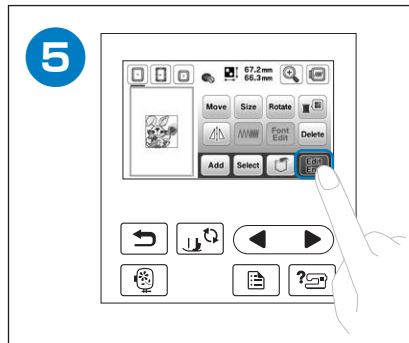
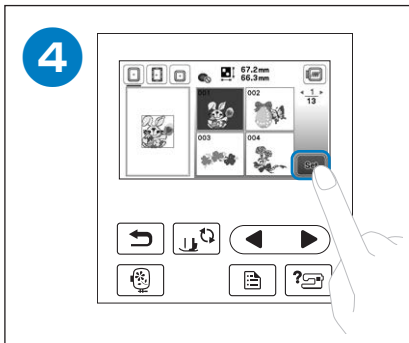
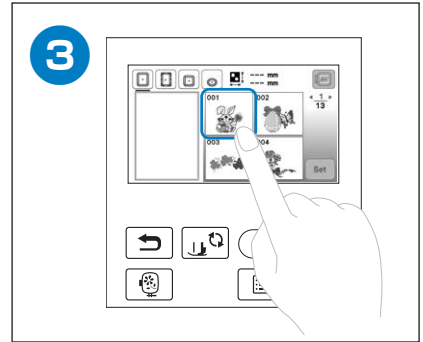
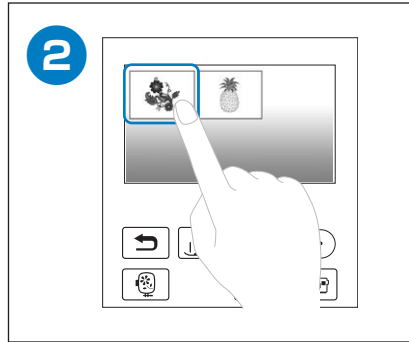
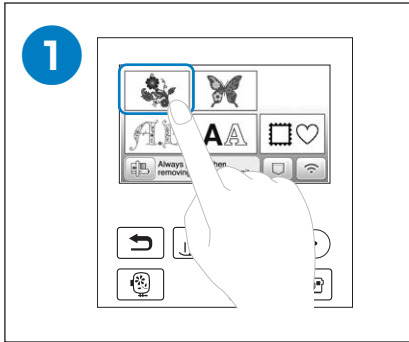

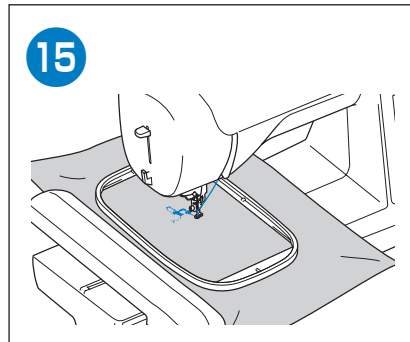
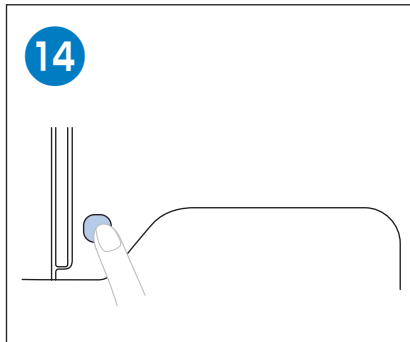
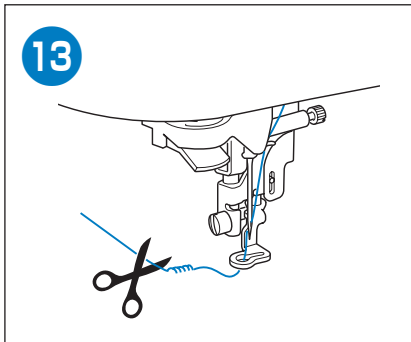

English  
German  
French  
Dutch  
Italian  
Spanish  
Portuguese-BR  
Russian  
888-L80/L82/K80



D029MT-001